

UFD

ATC Aero Ventiladores centrífugos línea industrial entrada sencilla, acoplamiento directo Álabes planos atrasados



La línea UFD de los Aero Ventiladores Centrífugos de simple entrada en acoplamiento directo Mca. ATC ha sido especialmente diseñada para los sistemas de inyección y extracción de aire en aplicaciones comerciales e industriales. Disponibles en 9 tamaños con diámetros de turbina desde 10 1/4" hasta 24 5/8", en simple ancho, distintas clases constructivas, rotaciones y diferentes posiciones de descarga, ofreciendo la gama de ventiladores centrífugos más versátil, eficiente y compacta con el rango más amplio en prestaciones de caudal-presión en el mercado.

Características principales

- Conjunto carcasa, cono de succión y soporte del motor fabricado en acero o acero inoxidable de diferentes calibres según tipo de clase del ventilador (I-II).
- Turbina centrífuga de simple ancho y de alta eficiencia y operación silenciosa con alabes planos atrasados estática y dinámicamente balanceada, fabricada en acero al carbón, acero inoxidable ó aluminio según aplicaciones.
- El proceso de prepintado con tratamientos químicos y posteriormente la aplicación electrostática de pintura poliéster en polvo horneada altamente resistente a la corrosión e intemperie en todos los componentes de los ventiladores centrífugos ATC es estándar.
- Disponible en 8 diferentes posiciones de descarga (TH, TAD, DB, BAD, BH, BAU, UB, TAU) con 2 distintas rotaciones del rotor (CW – CCW).
- Accionado por acoplamiento directo a los motores eléctricos de 2,4 y 6 polos de eficiencia premium, permite lograr las distintas relaciones de caudal-presión ofreciendo el ventilador centrífugo más versátil y vendido en el mercado.
- Construcción anti-chispa según clasificaciones de AMCA.



Accesorios disponibles

- Registro o Puerta de Inspección.
- Tubo de Dren.
- Tacones o resortes antivibratorios.
- Malla de protección en succión o descarga.
- Brida en descarga.
- Construcción anti-chispa.
- Recubrimientos especiales para aplicaciones de alta resistencia a la corrosión ó temperatura.

Nomenclatura

UFD - 15 - 4P - CW - I

1	2	3	4	5
---	---	---	---	---

1. Modelo del Ventilador.
2. Tamaño del Ventilador.
3. No. de polos del motor.
2P: 2 polos (3,500 rpm)
4P: 4 polos (1,750 rpm)
6P: 6 polos (1,150 rpm)
4. Rotación de la turbina:
CW - Sentido Reloj 
CCW - Sentido contra Reloj 
5. Clase Constructiva del Ventilador
I – Clase I
II – Clase II

UFD

ATC direct drive single inlet industrial centrifugal fans Backward inclined wheels



The UFD series are heavy duty single inlet direct drive centrifugal fans designed for ventilation and air conditioning systems, class I and class II performance in commercial and industrial applications. ATC UFD fans are available in 9 sizes with wheel diameters from 10 1/4" through 24 5/8", different performance classes, rotations and discharge positions, offering the line of most versatile, compact and energy efficient fans which can handle a wide range of airflow and pressure in the global market.

Construction features

- Housing, inlet cone and motor stand are made of air tight heavy gauge all welded steel or stainless steel construction.
- Backward inclined single width non-overloading wheels are constructed with welded steel, stainless steel or aluminum, statically and dynamically balanced at the factory and designed for optimum performance for most operating conditions.
- Electrostatically polyester applied powder coating is Standard on all ATC fans. For special requirements, please contact the factory.
- The fans are field rotatable to 8 standard discharges (TH, TAD, DB, BAD, BH, BAU, UB, TAU) and are available with clockwise (CW) or counter clockwise (CCW) wheel rotation.
- The UFD series are the ideal choice for direct drive ventilation applications by using the premium efficiency motors in 2, 4 and 6 poles in order to handle a wide range of airflow and pressure.
- AMCA classifications for spark resistant construction where hazardous, explosive or flammable conditions exist.

Optional accessories

- Access or clean-out doors.
- Drains.
- Vibration Isolators.
- Inlet & outlet screens.
- Flanged outlet.
- Spark resistant construction.
- Special protective coating for corrosion and high temperature.

Nomenclature

UFD - 15 - 4P - CW - I

1

2

3

4

5

1. Fan model.

2. Fan size.

3. Motor pole.

2P: 2 pole (3,500 RPM).

4P: 4 pole (1,750 RPM).

6P: 6 pole (1,150 RPM).

4. Impeller rotation:

CW - Clockwise ↻

CCW – Counter clockwise ↻

5. Fan class.

I – Class I

II – Class II

UFD

Especificaciones técnicas / Performance Data

Modelo	Motor		Tensión Tension	Corriente Current	Caudal a descarga libre Air flow @ 0°C.A.		Potencia sonora Sound power level
	RPM	HP			CFM	m3/hr	
UFD-10-2P	3500	1 1/2	230 /460	4.2 / 2.0	1850	3143	84
UFD-10-4P	1750	1/2					
UFD-10-6P	1150	1/2					
UFD-12-2P	3500	3	230 /460	7.2 / 3.6	3400	5777	92
UFD-12-4P	1750	3/4					
UFD-12-6P	1150	1/2					
UFD-13-2P	3500	5	230 /460	11.8 / 5.9	4600	7815	93
UFD-13-4P	1750	1					
UFD-13-6P	1150	1/2					
UFD-15-4P	1750	1 1/2	230 /460	5.2 / 2.6	3200	5437	80
UFD-15-6P	1150	3/4					
UFD-16-4P	1750	2	230 /460	8.0 / 4.0	4300	7306	84
UFD-16-6P	1150	3/4					
UFD-18-4P	1750	3	230 /460	9.8 / 4.9	5900	10024	88
UFD-18-6P	1150	1					
UFD-20-4P	1750	5	230 /460	15.0 / 7.5	7800	13252	92
UFD-20-6P	1150	1 1/2					
UFD-22-4P	1750	7 1/2	230 /460	23.0 / 11.5	10400	17670	96
UFD-22-6P	1150	2					
UFD-24-4P	1750	15	230 /460	42.0 / 21.0	13750	23361	99
UFD-24-6P	1150	5					

Curvas de operación / Performance curves

UFD-10

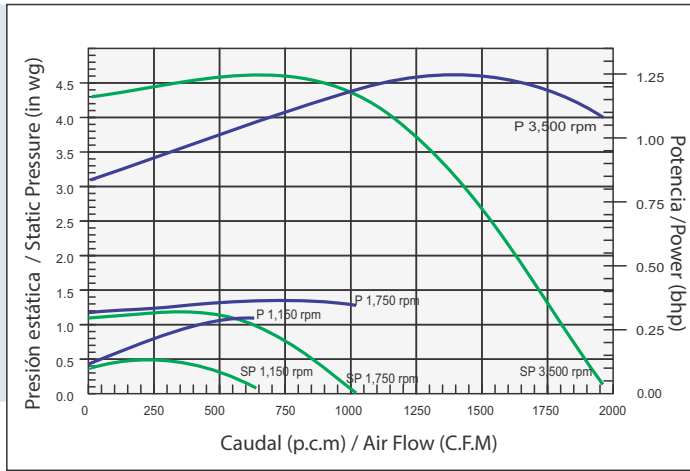

UFD-12

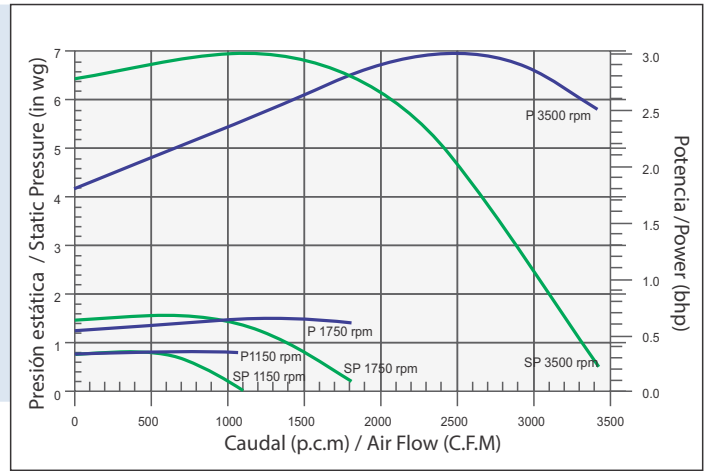

UFD-13

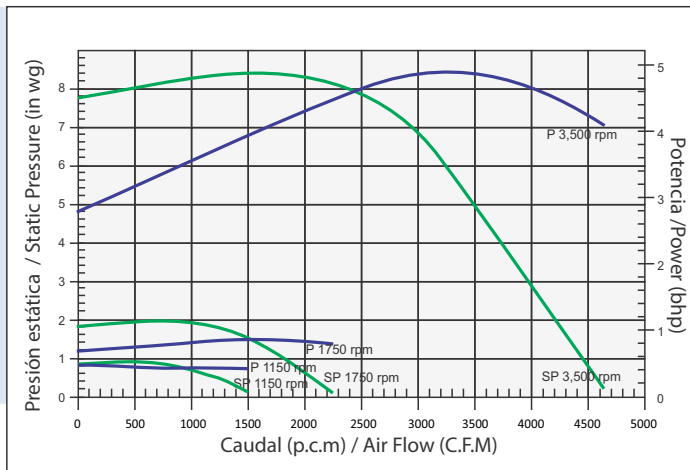

UFD-15

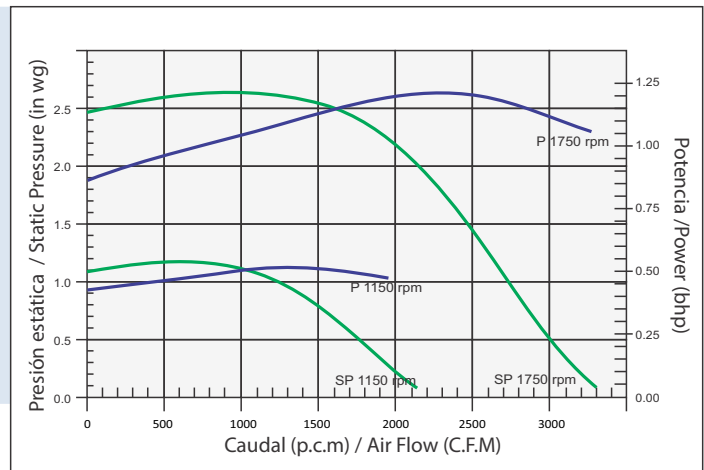

UFD-16

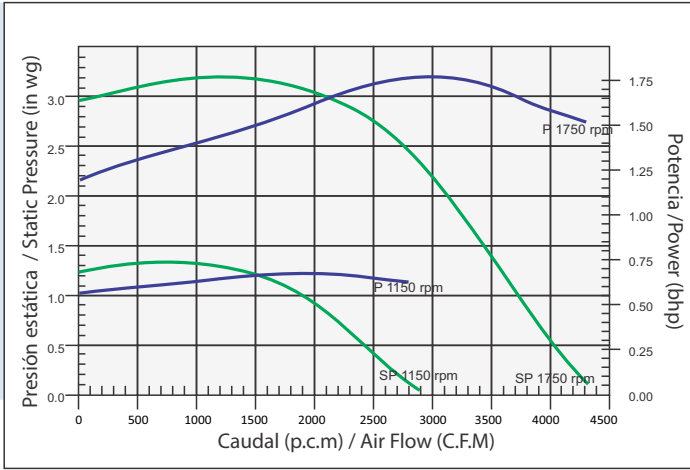

UFD-18

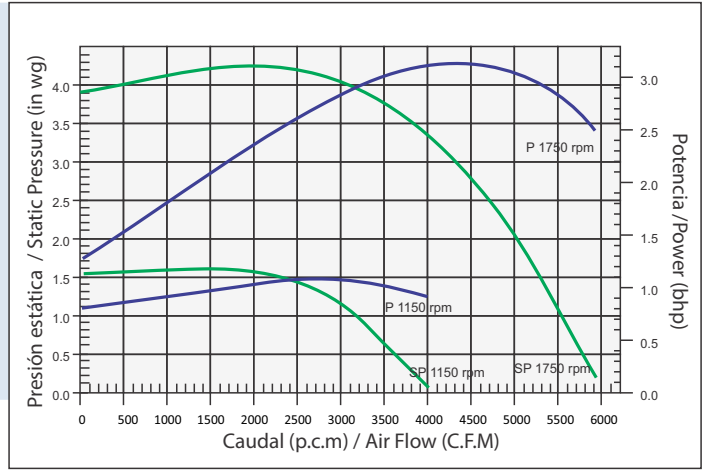

UFD-20

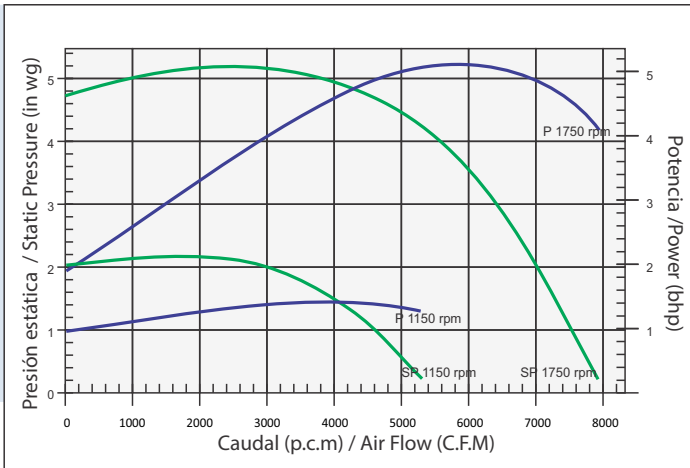

UFD-22

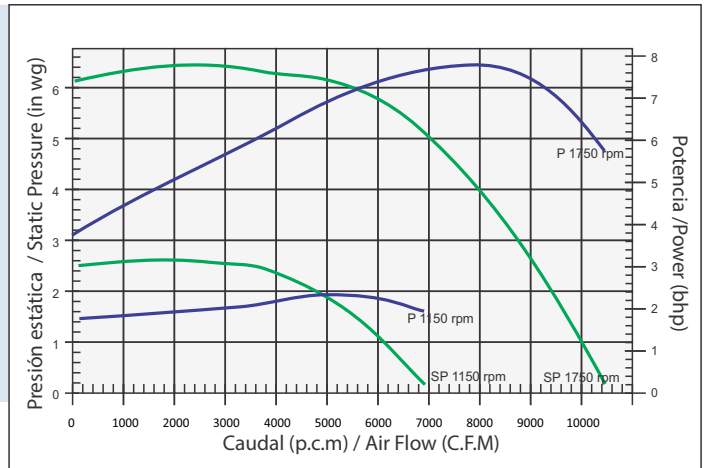

UFD-24

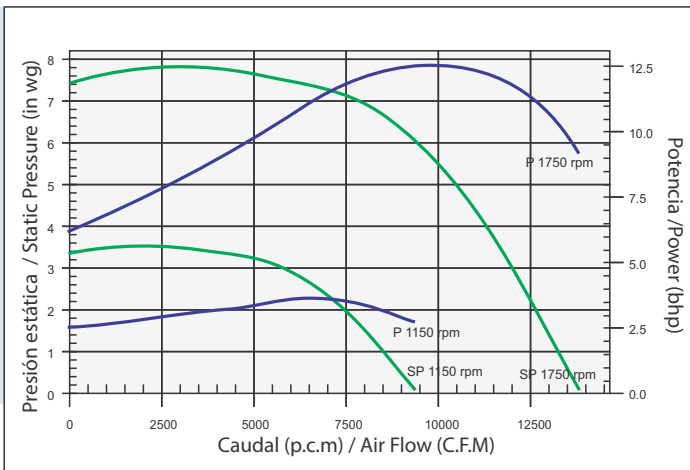

Todas las capacidades están basadas en la Densidad Estándar de Aire de 0.075 Lb/ft³ @ 70°F y 0 pies de Elevación: 1.2 kg/m³ @ 21°C y 0 mt
 (All Capacities are based on Standard Air Density of 0.075 Lb/ft³ @ 70°F and 0 Ft elevation: 1.2 kg/m³ @ 21°C and 0 mt)

UFD

Dimensiones generales / Dimensions

Vista lateral
Side view

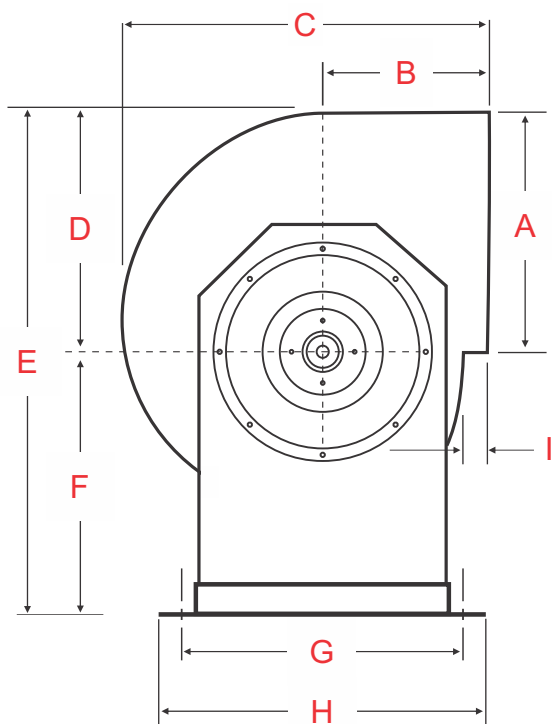

Vista frontal
Front view

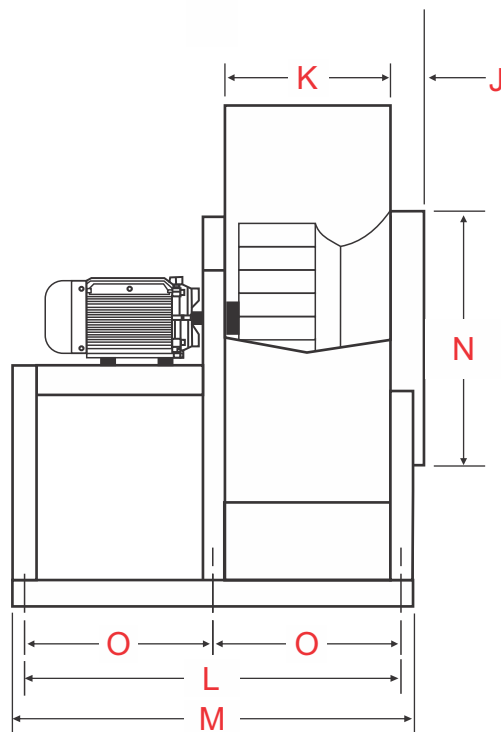

Vista planta para barrenos
Foundation plan

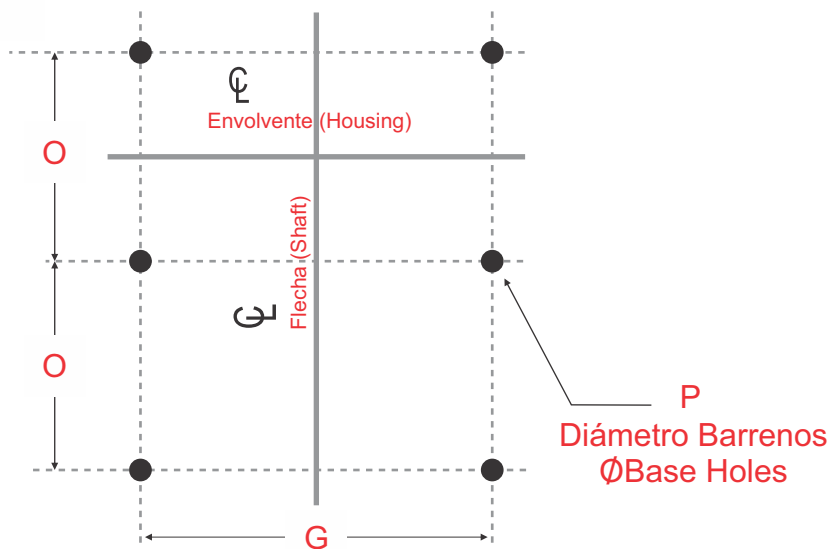

UFD

Dimensiones generales / Dimensions

Modelo	Diámetro Turbina (in)	Área de Descarga (ft ²)	Pulgadas (Inches)														Peso Aprox. c/motor				
			Área Succión (ft ²)	A	B	C	D	E	F	G	H	I	J	K	L	M	N	O	P	Aprox Weight w/motor	Lb
UFD-10	10 1/4	0.630	0.644	11 1/4	8 1/2	19	10 5/8	24 3/4	14 1/8	15	16 1/2	2	2 1/4	8 1/4	22 1/2	24	10 3/4	10	3/8	119	54
UFD-12	12 1/2	0.994	0.887	13 5/8	10	22 7/8	12 15/16	27 3/4	14 13/16	17 3/4	19 1/4	2	2 1/4	9 3/8	26 3/4	28 1/4	13 1/2	11 1/4	3/8	233	106
UFD-13	14	1.186	1.098	15 1/4	11	24 7/8	14 1/4	30	15 3/4	18 3/4	20 1/4	2 1/4	2 1/4	10 3/8	27 7/8	29 3/8	14 3/4	12 3/8	3/8	238	108
UFD-15	15 1/8	1.484	1.333	16 7/8	12	27	15 13/16	33 3/4	17 15/16	21	22 1/2	2 1/4	3 1/4	11 3/8	30 3/8	31 7/8	16 1/2	12 7/8	1/2	246	112
UFD-16	16 11/16	1.816	1.616	18 5/8	13	29 3/4	17 1/2	36 3/4	19 1/4	22 1/2	24	2 1/4	3 1/4	12 1/2	30 1/2	32	18 1/4	13	1/2	271	123
UFD-18	18 9/16	2.181	1.995	20 3/4	14	32 1/2	19 5/6	40 1/2	21 3/16	26 1/4	28 1/4	2 1/2	3 1/4	13 7/8	34 1/2	36 1/2	20	15 1/4	1/2	345	157
UFD-20	20 7/16	2.639	2.382	22 7/8	15 1/2	36 1/8	21 3/8	44 1/2	23 1/8	27 3/4	29 3/4	2 1/2	3 1/4	15	35 1/2	37 1/2	22	16 1/4	1/2	378	172
UFD-22	22 9/16	3.273	2.944	25 1/8	17	39 3/4	23 9/16	49 1/4	25 11/16	30 1/4	32 1/4	2 3/4	3 1/4	16 7/8	37 5/8	39 5/8	24 1/2	17 3/8	1/2	462	210
UFD-24	34 5/8	4.050	3.549	27 5/8	19	43 3/4	25 15/16	53 1/4	27 5/16	30 1/4	32 1/4	3 1/4	4 1/4	18 1/2	39 5/8	41 5/8	27 1/4	19 3/8	1/2	673	306